

Outline of ICHARM and its strategy to contribute to flood disaster reduction

January 9, 2007

Kazuhiko FUKAMI

**Hydrologic Engineering Research Team,
ICHARM, Public Works Research Institute**

k-fukami@pwri.go.jp

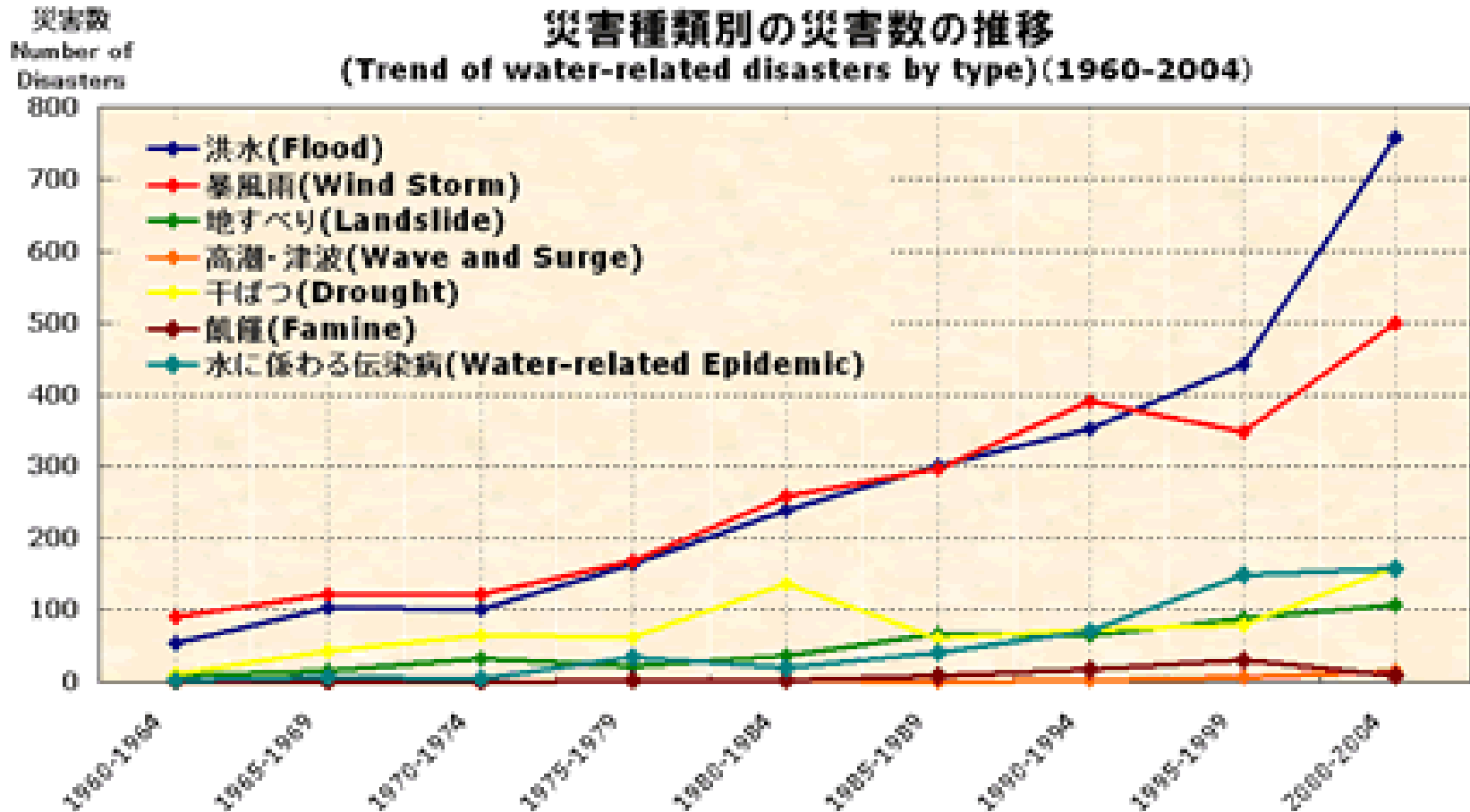

‘Disaster with death toll of more than 10 or victims of more than 100’

Number of disasters by flood or storm is large and it is increasing.

災害数
Number of
Disasters

大陸別の災害数の推移 (Trend of water-related disaster by continent) (1960-2004)

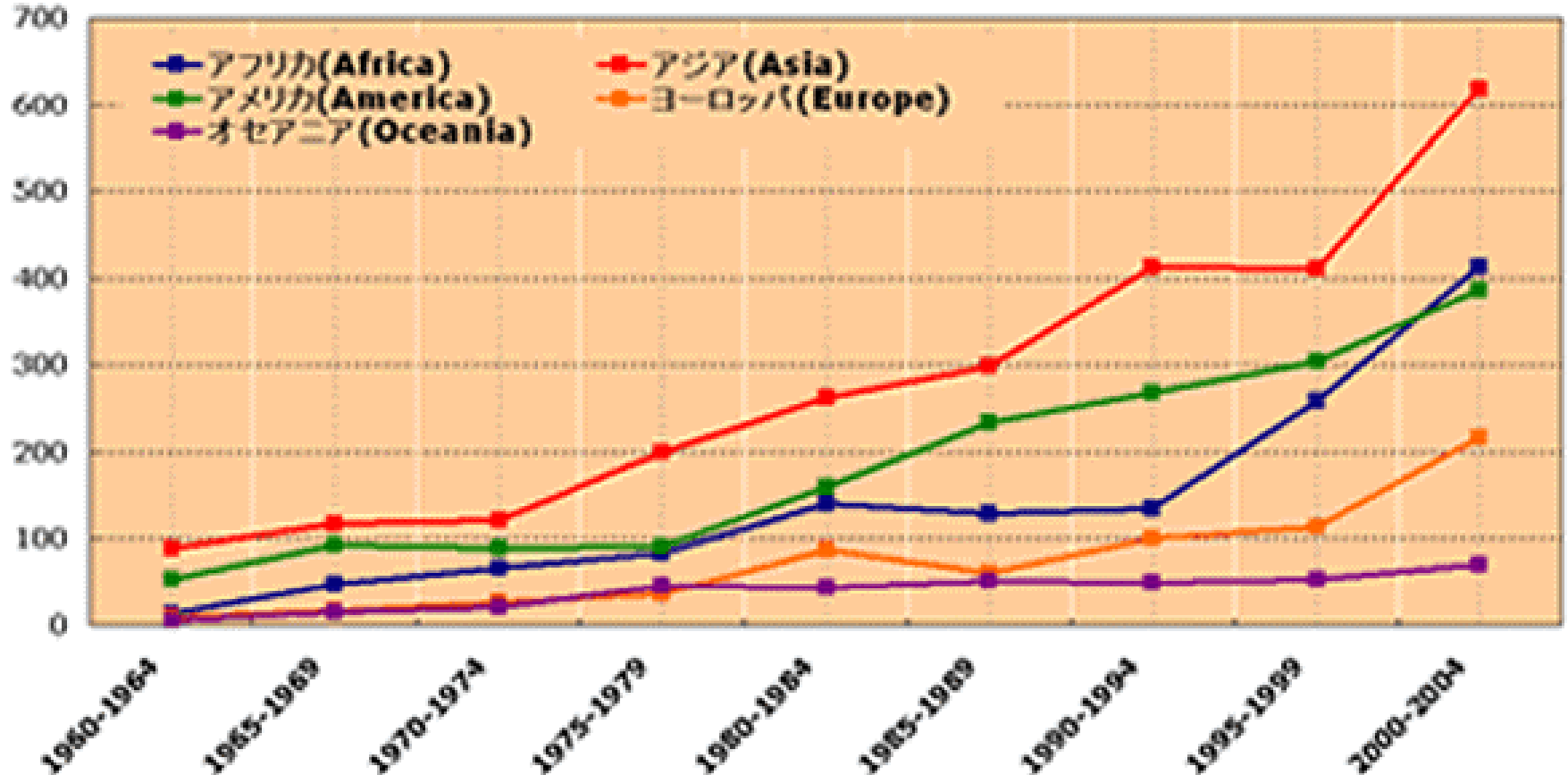

Water-related disasters in Asian region accounts for one third of world's total water-related disasters. The number is also increasing.

**International Centre for
Water Hazard and
Risk Management**

(ICHARM)



under the auspices of UNESCO

List of IHP-UNESCO Centre

Organization	Name	Location(country)
UNESCO-IHE Institute for Water Education		Delft (The Netherlands)
European Regional Centre for Ecohydrology		Lodz (Poland)
IHP-HELP Centre for Water Law, Policy and Science		Dundee (U.K.)
International Centre for Water Hazard and Risk Management	ICHARM	Tsukuba (Japan)
International Centre on Qanats and Historic Hydraulic Structures	ICQHHS	Yazd (Iran)
International Research and Training Centre on Erosion and Sedimentation	IRTCES	Beijing (China)
International Research and Training Centre on Urban Drainage	IRTCUD	Belgrade (Serbia and Montenegro)
Regional Centre on Urban Water Management	RCUWM	Tehran (Iran)
Regional Centre on Urban Water Management for Latin America and the Caribbean		Cali (Colombia)
Regional Centre for Training and Water Studies of Arid and Semi-arid Zones	RCTWS	Cairo (Egypt)
Regional Humid Tropics Hydrology and Water Resources Centre for South-East Asia and the Pacific	HTC Kuala Lumpur	Kuala Lumpur (Malaysia)
Water Centre for Arid and Semi-arid Zones of Latin America and the Caribbean	CAZALAC	La Serena (Chile)
Water Centre for the Humid Tropics of Latin America and the Caribbean	CATHALAC	Panama (Panama)

Launch of the International Flood Initiative (IFI) was declared at a session of the UN World Conference on Disaster Reduction in Kobe in January, 2005.



International Strategy
ISDR
for Disaster Reduction

Welcome to Hyogo

World Conference

.....
18-22 January 2005, Kobe, Hyogo, J

International Flood Initiative (IFI)

Mission

Promote **an integrated approach to flood management**

by **reducing the risk** of social, environmental and economic effects that result in and from floods and **increasing the benefits** from floods and the use of flood plains

Implementation

UNESCO, WMO, UNU, UN-ISDR, IAHS . . .

Secretariat : ICHARM

Objective of ICHARM

- To function as the global Center of Excellence to provide and assist implementation of best practicable strategies to localities, nations, regions and the world to manage the risk of water related hazards including floods, droughts, land slides, debris flows and water contamination.
- At the first stage, the priority is flood-related disasters

Guiding Principles of ICHARM

- **Needs Driven** rather than supply driven
- **Advocate Integrated Risk Management** (avoidance, reduction, transference and acceptance) in multifaceted societal, economical, institutional and cultural conditions as well as technological availability.
- **Produce Policy Effective Information**
- **Research Development and Capacity Building** together
- **Alliance** with all the related organizations and initiatives



**1st Advisory Board Meeting in Tsukuba
(Sept. 15, 2006)**

Member list of ICHARM Advisory Board (2006-2008)

Members elected by IHP Intergovernmental Council:

Group 1 (Western Europe and North America): Mr. Eugene Z. Stakhiv (USA)

Group 2 (Central and Eastern Europe and Russia): Mr. Maciej Zalewski (Poland)

Group 3 (Latin America and Caribbean): Mr. Carlos Eduardo Tucci (Brazil)

Group 4 (Asia and Oceania): Mr. Muhammad Akram Kahlowan (Pakistan)

Group 5a (Africa): Mr. Abou Amani (Niger)

Group 5b (Arab States): Mr. Anwar George Hanne Jiries (Jordan)

Members appointed by the Chief Executive of PWRI:

Director General of UNESCO (representative)

Secretary General (representative), World Meteorological Organization (WMO)

Director, International Strategy for Disaster Reduction (UN-ISDR)

Rector, United Nations University (UNU)

Rector, UNESCO Institute for Water Education (UNESCO-IHE)

Vice President, Japan International Cooperation Agency (JICA)

Vice Minister for Technical Affairs, Minister of Land, Infrastructure and Transport



1st Advisory Board Meeting in Tsukuba (Sept. 15, 2006)

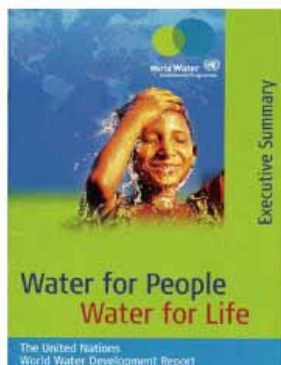

UN WWDR(2003)
Executive Summary



Our Web

- Contributing to the **World Water Development Report (WWDR)** compiled by the **World Water Assessment Programme (WWAP)** by developing various indicators and presenting case studies in the risk management domain
- Promoting the **International Flood Initiative (IFI)**
- Expanding the **Global Flood Alert System (GFAS)** in liaison with the International Flood Network (IFNet)
- Conducting interdisciplinary studies on water-related disaster reduction measures for foreign rivers such as the **Mekong River, the Chao Phraya River and the Chang Jiang River**
- Developing procedures for hydrological observations and data processing

Research

Data/
Information

Results/
Outcomes

Curriculum

Participation

Knowledge

Network

Information Networking

Training



Flood Hazard Mapping Training

- Developing **database** regarding water-related disasters worldwide in various areas such as meteorology, hydrology, damage statuses, and risk management systems
- Creating an international/interdisciplinary network of researchers, administrators and those who completed training courses through the **Web** and **newsletters**

- Planning and conducting training for administrators and researchers mainly in developing countries
[Examples of the Training Courses]
- **Flood hazard mapping**
- **River and dam engineering**
- **Tsunami disaster prevention (in preparation)**

Research, Training and Information networking activities would be promoted in a combined manner

Proactive

Reactive

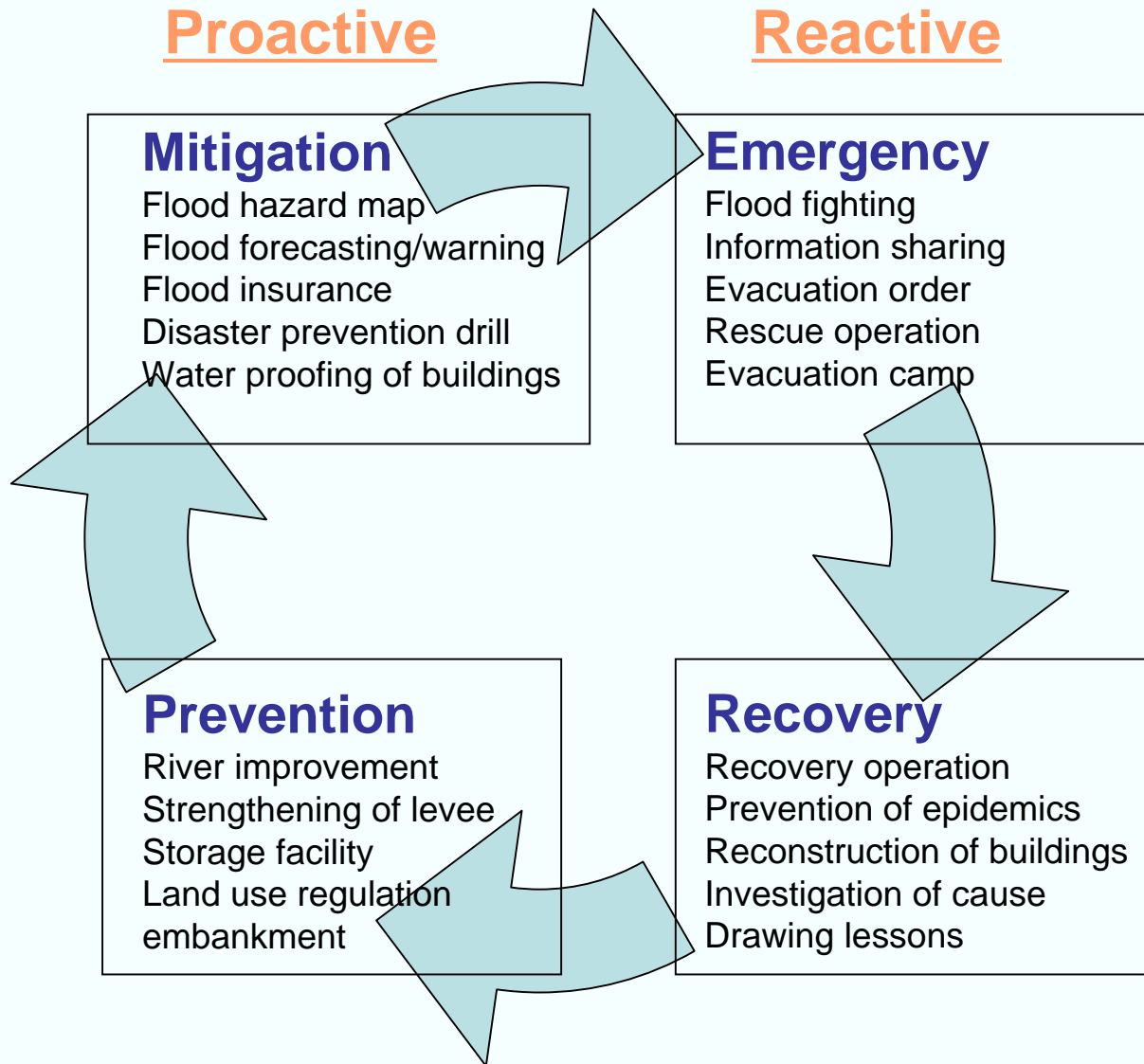

**Integrated risk management considering the total
balance of proactive and reactive measures is important**

ICHARM

Director: Prof. Kuniyoshi Takeuchi (Professor, University of Yamanashi / Chairman, Japan National Committee for the UNESCO International Hydrological Programme (IHP))

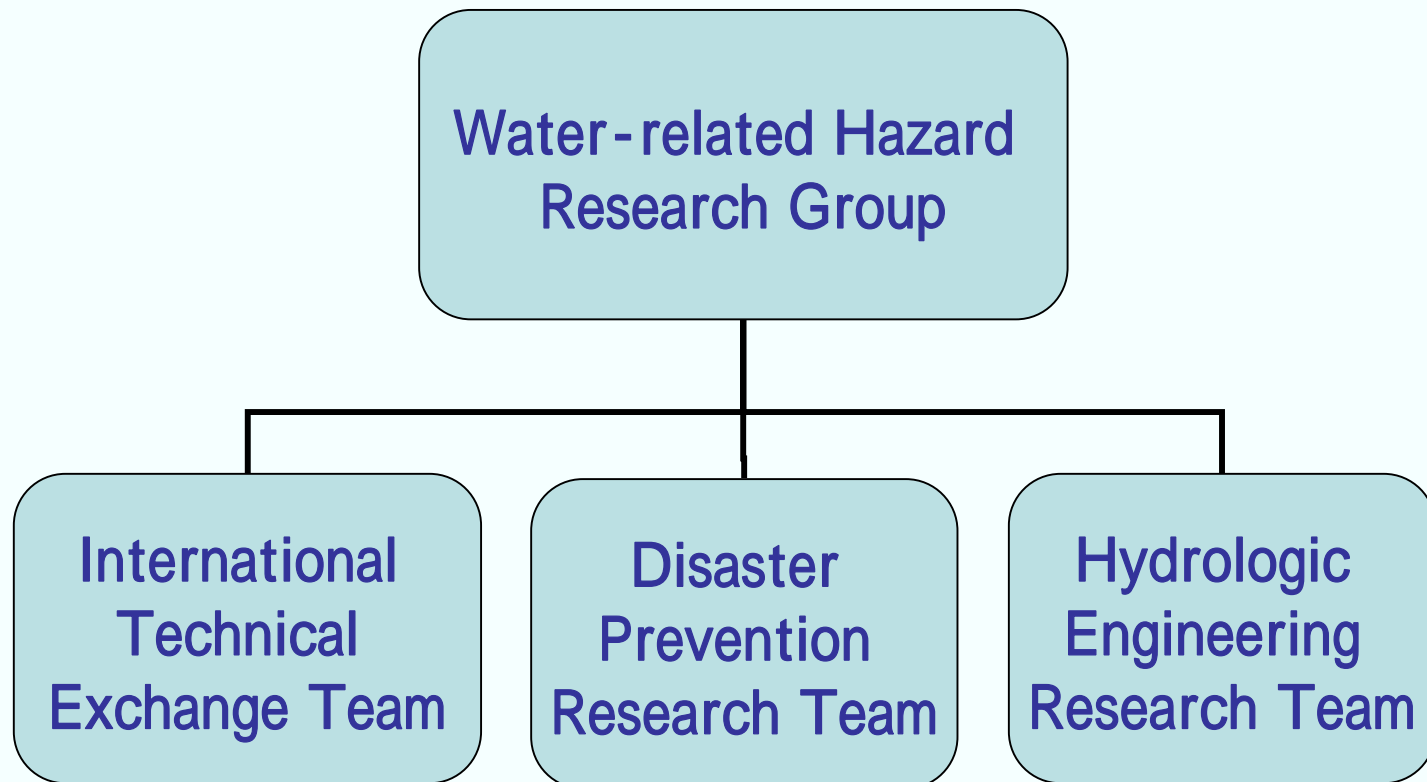

Research

- **Local studies** (Identification of the real needs of the people in diverse localities)
→ Diagnosis & Prescription
 - ICHARM Local Study Series
 - ICHARM Flood Year Book
- **Satellite-based Flood Forecasting & Warning** (with JAXA, IFNet/GFAS etc.)
- **Flood Hazard Mapping:**
 - methodologies to map in remote localities with poor data
 - effective and beneficial use under different local conditions

Global Flood Alert System (GFAS)

<http://gfas.internationalfloodnetwork.org/gfas-web/>

Verification of applicability of satellite-based rainfall for flood-runoff analysis

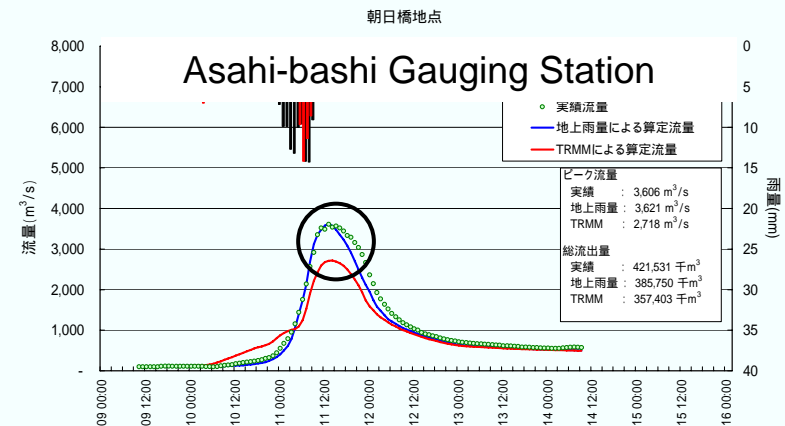
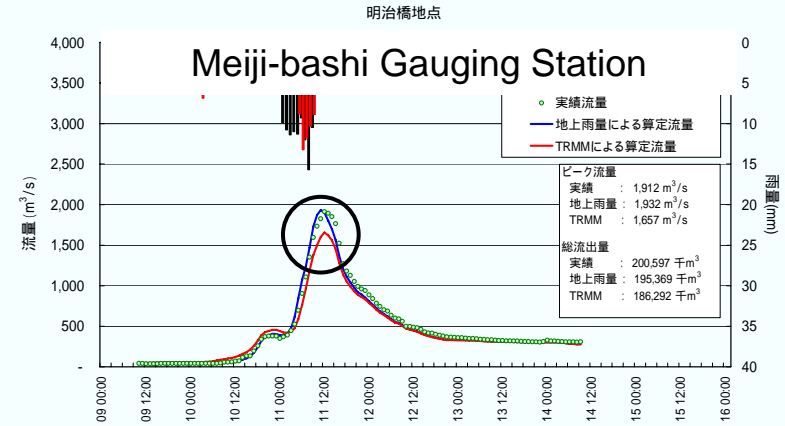
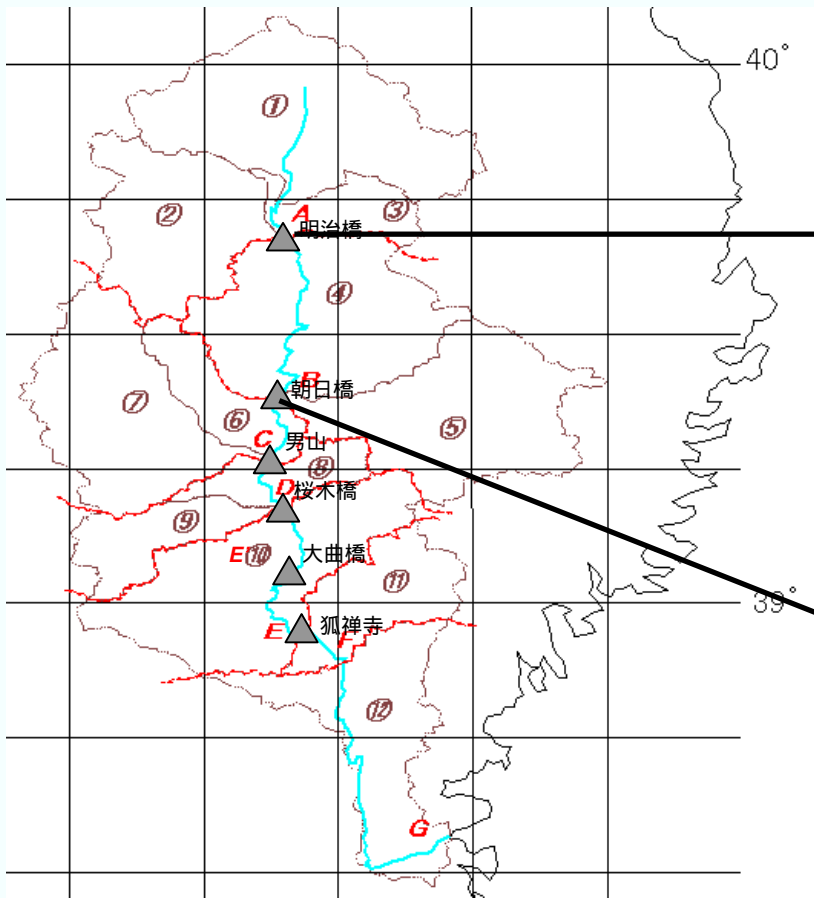

Peak discharges are under-estimated from around 10 to 25%. (dH=0.3-0.8m)
Estimation of arrival time of flood peaks are consistent with real situations.
Errors of total discharges for this event are almost smaller than those of peaks.

A computer software package specifically for flood runoff analyses with GUI using not only ground-based but also satellite-based rainfall data

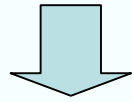

“Integrated Flood Analysis System (IFAS)”

being developed by

Joint research (FY2005-2006) among

ICHARM/PWRI, Infrastructure Development Institute (IDI),
and nine major civil-engineering consulting companies, i.e.,
CTI Engineering Co.,Ltd, NIKKEN Consultants,Inc.,
Yachiyo Engineering Co.,Ltd., Pacific Consultants Co.,Ltd.,
Tokyo Construction Consultants Co.,Ltd., NEWJEC Inc.,
Nippon Koei Co.,Ltd., CTI Engineering International Co.,Ltd.,
& Kokusai Kogyo Co.,Ltd.



Design concept of IFAS

- Availability in poorly-gauged basins
 - Utilization of not only ground-based but also satellite-based rainfall data
 - A default flood runoff calculation model with globally-available GIS
- User-friendly graphical interfaces for data input, analysis & output, but small & light by focusing on flood forecasting and runoff analyses
- Easy & flexible maintenance and upgrade of runoff calculation models
 - A default rainfall-runoff model will be prepared, but any model more suitable for each region can replace it and utilize the common interfaces.
- Distribution of executables, free of charge (plan)



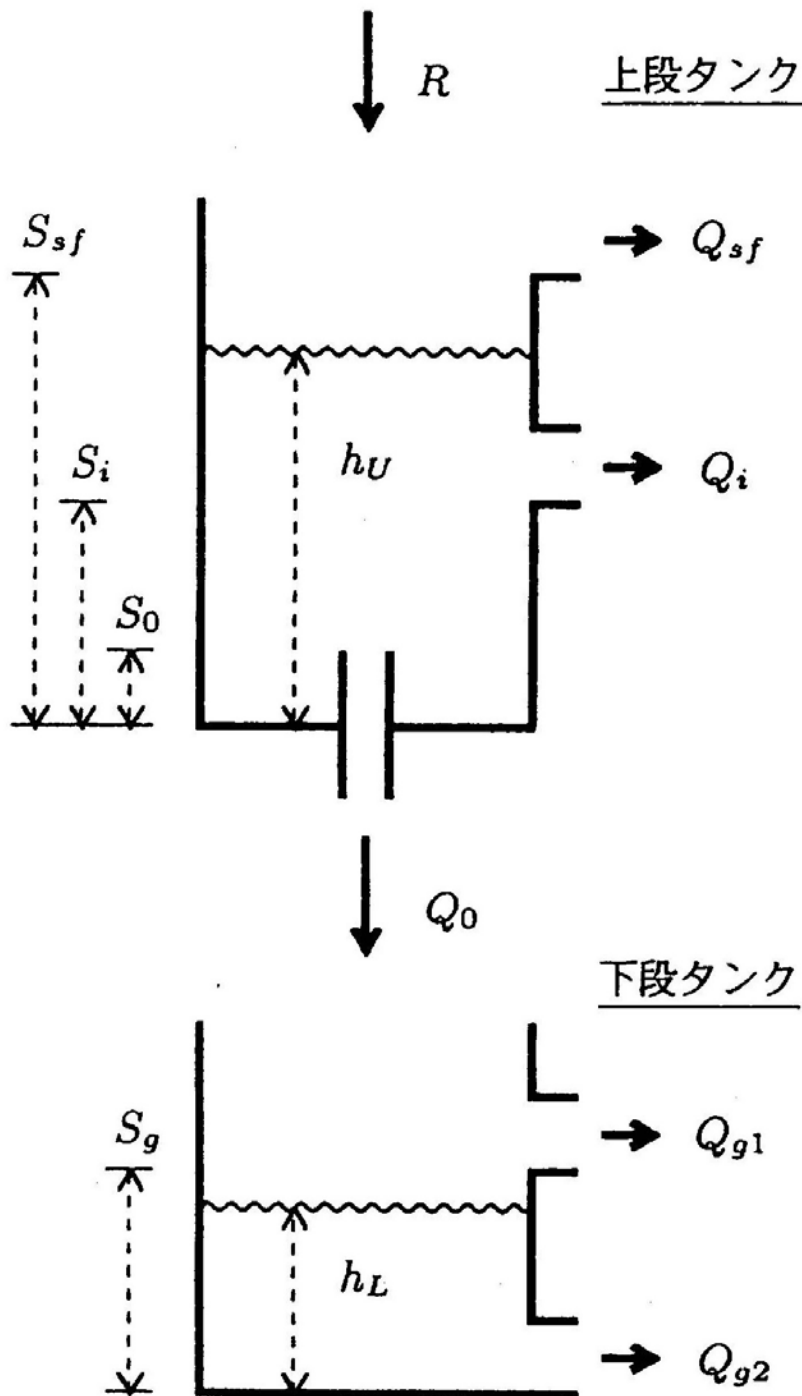

PWRI Conceptual Distributed-Parameter Hydrologic Model (PDHM, Ver.2) by Suzuki et al.(1996)

Upper tank:

Q_{sf} : surface runoff (Manning eq.)

Q_i : subsurface runoff (Darcy)

Q_o : percolation (Darcy)

Lower tank:

Q_{g1} : Unconfined groundwater runoff

Q_{g2} : Confined groundwater runoff

River routing:

Kinematic-wave method

Structure of Integrated Flood Analysis System (IFAS)

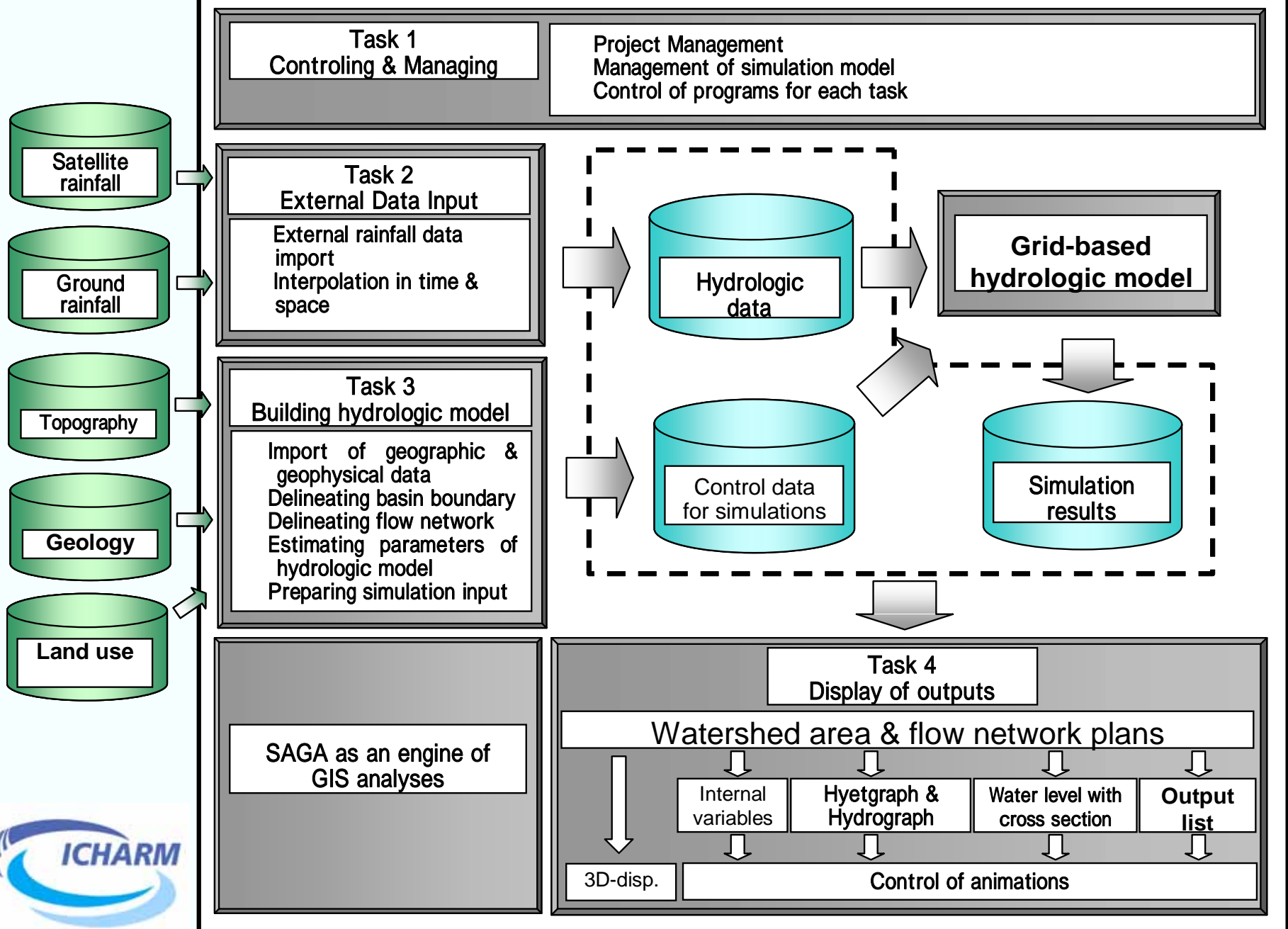

GIS analyses & hydrologic model building (Task 3)

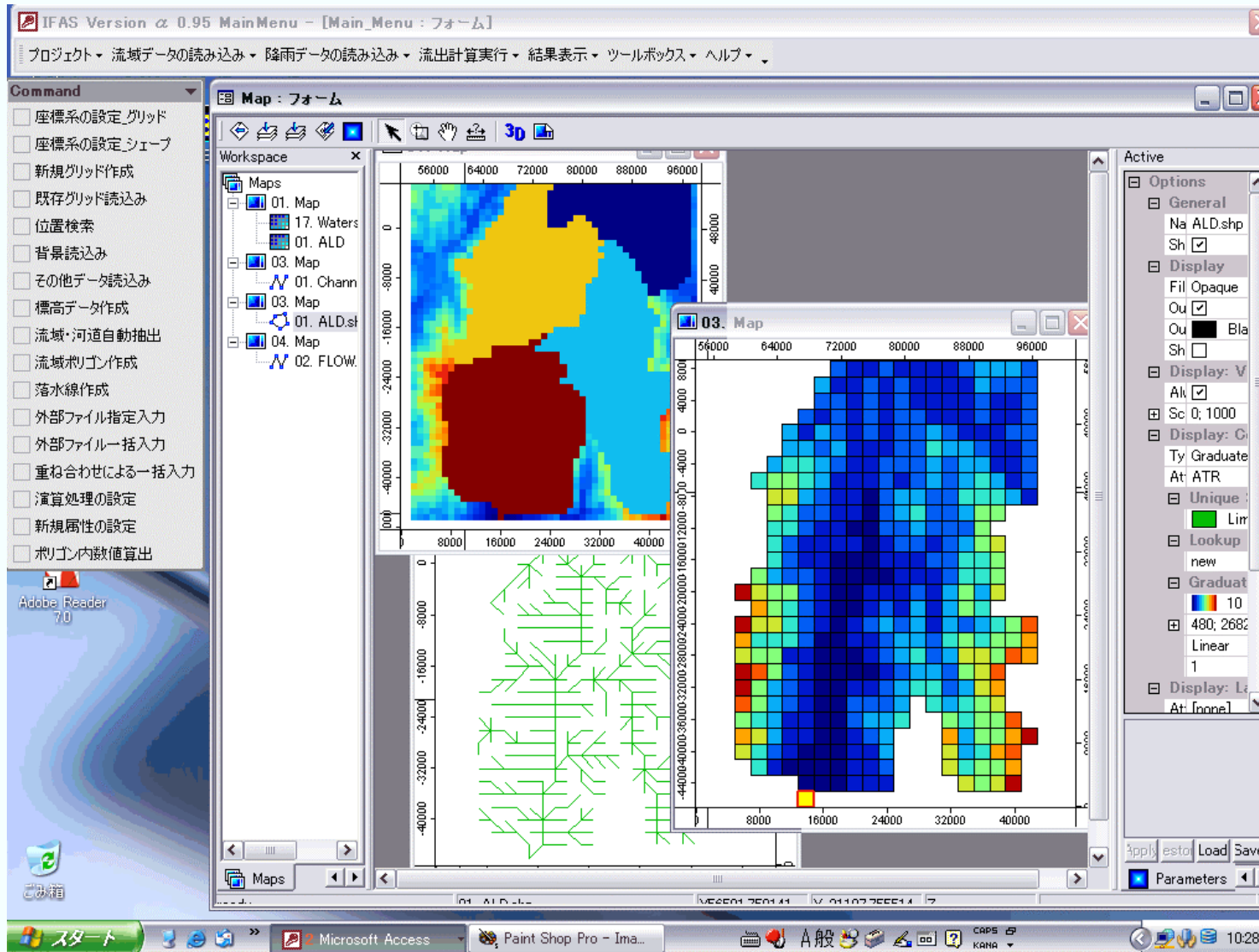

As of alpha-version, August 2006



Information Networking

- **Collection of local site-specific information**
 - **Local Disaster Karte**
- **Emergency response, PCPD (Post crisis and post disaster) program**
- **Analyses of global data sets**
 - **policy effective information**
 - **WWDR ← Flood risks (WWDR2 Chapt 10 Managing Risk)**

Capacity Building

- **Training courses**
 - Flood hazard mapping course started in 2004
 - River and Dam engineering course started in 1969
- **Aftercare program** in trainees local communities
- **Master course on Flood Disaster Mitigation** with National Graduate Institute for Policy Studies (in preparation)

Miyagawa River Flood Hazard Map

[Ise City Flood Evacuation Map]

How to read the map

Anticipated inundation depth
(demarcation according to rank)

- Inundation depth 5 m or more
- Inundation depth less than 5 m
- Inundation depth less than 2 m
- Inundation depth less than 1 m
- Inundation depth less than 0.5 m

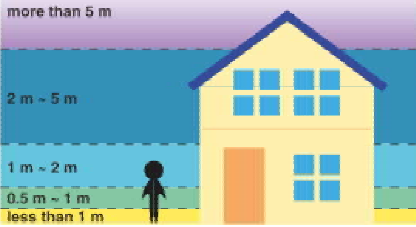

Legend

- 1 Evacuation centers
- 1 Disaster prevention organizations
- Flood Fighting storages
- Emergency radio stations
- Sirens

洪水ハザードマップの情報
浸水範囲と浸水深
避難路、避難場所、危険箇所
さらに流向、流速

住民: 危険認識、洪水回避のインセンティブ
適切かつ迅速な避難の推進

行政: 避難の遂行

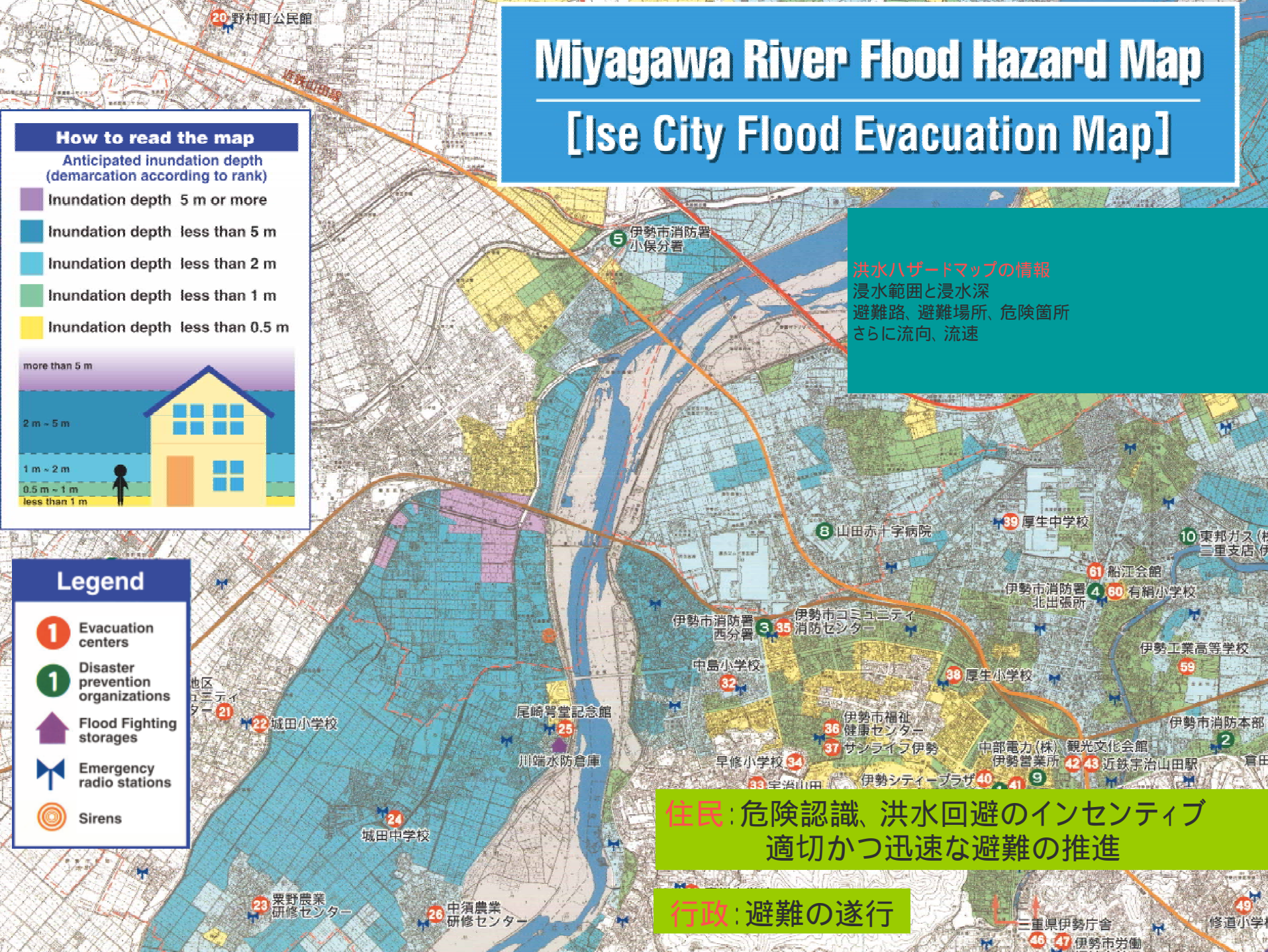

Objectives of FHM Training Course at ICHARM

- (a) To acquire **professional knowledge** of hydrology, hydraulics and river engineering necessary to produce flood hazard maps,
- (b) To understand **the effectiveness of flood hazard maps** and how to disseminate and utilize them for people,
- (c) To acquire methods to enhance **people's capability** and promote **public awareness** to mitigate flood damage,
- (d) To acquire an understanding of the way to produce and apply flood hazard maps **for participants' own country/region**

Asia-Pacific Water Forum (APWF)

<http://www.apwf.org>

- Launched during the WWF4 in Mexico
- Independent, non-profit, non-partisan, and non-political network
- to contribute to sustainable water management in order to achieve the targets of the MDGs in Asia-Pacific region
- **3 Priority themes**
 - Water Financing
 - **Disaster Management**
 - Water for Development and Ecosystem

Thank you very much
for your attention!

<http://www.icharm.pwri.go.jp/>

Fukui City on the left bank side of the Asuwa River (photographed on July 18)



Fukui City on the left bank side of the Asuwa River (photographed on July 18)